

2304/2305

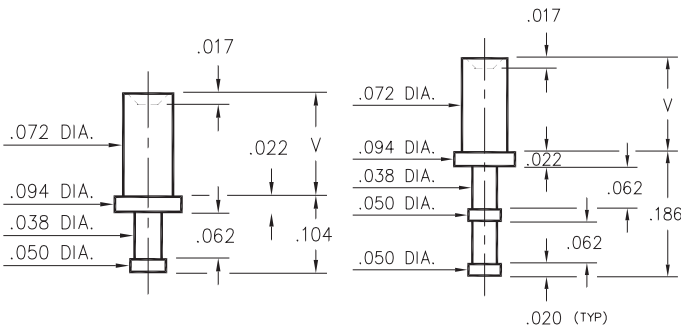

- X -	Board Thickness	Length V
1	.031	.051
2	.062	.082
3	.094	.113
4	.125	.145

2304-X-00-XX-00-00-07-0
Swage mount in .076 hole

2305-X-00-XX-00-00-07-0
Swage mount in .076 hole

2503

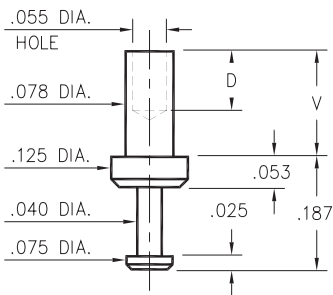

- X -	Board Thickness	Length V	Depth D
1	.031	.078	.068
2	.062	.109	.098
3	.094	.141	
4	.125	.172	

2503-X-00-XX-00-00-07-0
Swage mount in .082 hole

2704

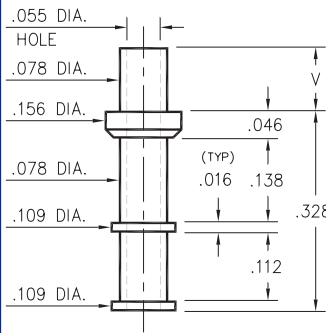

- X -	Board Thickness	Length V
1	.031	.075
2	.062	.105
3	.094	.135
4	.125	.165

2704-X-00-XX-00-00-07-0
Swage mount in .082 hole

2306/2307/2311

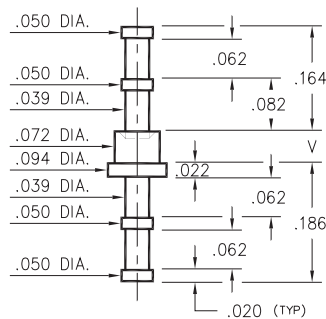
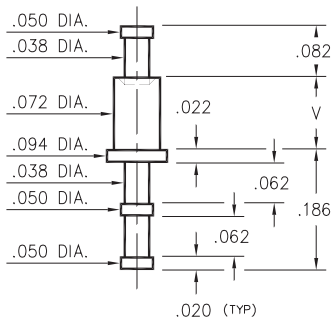
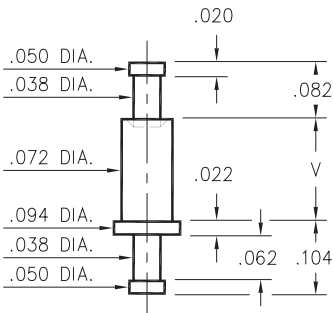

- X -	Board Thickness	Length V
1	.031	.051
2	.062	.082
3	.094	.113
4	.125	.145

2306-X-00-XX-00-00-07-0
Swage mount in .076 hole

2307-X-00-XX-00-00-07-0
Swage mount in .076 hole

2311-X-00-XX-00-00-07-0
Swage mount in .076 hole

SPECIFICATIONS

PIN MATERIAL:
Brass Alloy 360, 1/2 Hard
Swage pins are annealed

DIMENSION IN INCHES
TOLERANCES ON:
LENGTHS: ±.005
DIAMETERS: ±.002
ANGLES: ± 2°

ORDER CODE: 2XXX - X - 00 - XX - 00 - 00 - 07 - 0

BASIC PART #

SPECIFY PIN FINISH:

- 01 200μ" TIN/LEAD OVER NICKEL
- 80 200μ" TIN OVER NICKEL
- 44 300μ" SILVER OVER COPPER
- 50 300μ" ELECTRO-SOLDER (60/40 SnPb)

